

Current Probe

BST CU-05

FEATURES

- High Dynamic Range
- Very small size
- Anodized Aluminium Housing
- Rugged Housing
- Calibration

APPLICATION

- Crash Test
- General Current Measuring



DESCRIPTION

The model BST CU-05 is a sensor to detect current on a cable, based on Hall effect technique. This sensor is for instrumentation for impact testing or many other tests. Due to the 4-wire configuration it is connectable to all data acquisition systems. The very light weight and small size of the sensor makes it easy to mount it on difficult positions at the car for a crash test or for shock test application.

Due to the anodized aluminium housing it can be used for crash tests. With a 6 m, very rugged, shielded and flexible 4-wire cable all common connectors are mountable. As an option, we supply the sensor with a Dallas ID and a Shunt resistor in the connector. A calibration for the sensor is obligatory.

DIMENSIONS

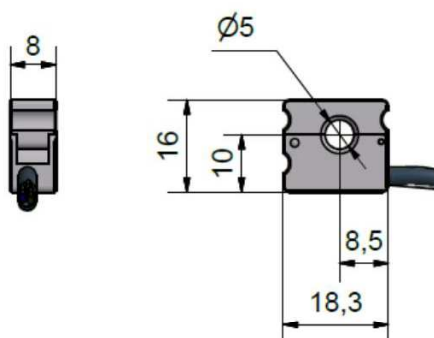

SPECIFICATION ACCELEROMETER

All data are typical at 23 °C AND 10 VDC SUPPLY.

Range (g)	15 A	40 A
Sensitivity typ. (mV/g)	3.5 mV/V/A	2.5 mV/V/A

ELECTRICAL PERFORMANCES

Supply voltage	5 to 10 VDC
Current Consumption	17 mA max.
Zero measurement output	25 mV typ.

ENVIRONMENTAL PERFORMANCES

Dynamic Range	10 kHz min.
Non-Linearity	+/- 1.5 % of FSO
Operation Temperature	- 20 °C to + 80 °C
Storage Temperature	- 50 °C to + 120 °C
Hole for Cable	5.0 mm
Housing Material	Aluminium, anodized
Dimensions	18.3 x 16.0 x 8.0 mm (l x w x h)
Weight Housing	12 gram without cable
Cable	integrated, 5-wire shielded, AWG 30
Cable Length	6 m
Cable Material	PUR, black
Cable Weight	12 grams per meter, Ø 3.0 mm

CABLE CODE

red = Excitation +
black = Excitation -

green = Signal +
white = Signal -

ORDER INFORMATION

BST CU-05-6Z
CU = Model name
05 = max. Cable diameter
6 = 6 m Cable
Z = no connector

OPTIONAL

Additional Cable Length
Connector
Dallas ID
TEDS
Shunt resistor