

Capacitive Accelerometer

BST SEA 57K1 Uniaxial

FEATURES

- Stainless Steel Housing
- Protection Class IP68
- DC Response (0 Hz) to 2500 Hz
- High Voltage Output
- Very Low Noise
- Calibration

APPLICATION

- Wind Energy
- Truck and Buses
- Train
- Civil Engineering
- Rugged Applications



DESCRIPTION

The model BST SEA 57K1 is a uniaxial accelerometer based on variable capacitive technology with a very good Signal-to-Noise Ratio. The accelerometers are designed for relatively low amplitudes and high resolution. Due to the 4 screws the sensor is easy to mount. The sensor has 6m very high rugged and flexible cable. This makes it possible to connect the sensor on data acquisition systems. It operates between 5 and 28 VDC unregulated. The housing is very rugged and has an IP 68 Grade due to the Stainless Steel. As an option, we supply the sensor with connector, Dallas ID or TEDS module. A calibration for the sensor is obligatory.

DIMENSIONS

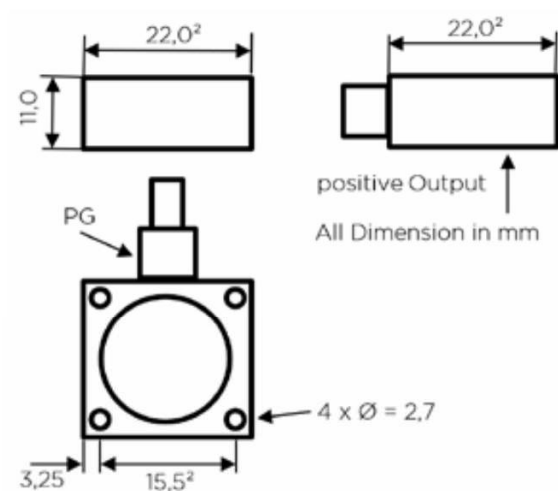

SPECIFICATION ACCELEROMETER

All data are typical at 23 °C AND 10 VDC SUPPLY.

Range (g)	2	5	10	25	50	100	200
Frequency (Hz)	0-250	0-300	0-450	0-1,000	0-1,500	0-2,000	0-2,500
Sensitivity (mV/g) (Differential)	2000	800	400	160	80	40	20
Noise (µg/root Hz)	7	12	18	25	50	100	200

Single Ended Mode (3-wire) is half of the Sensitivity from differential Signal.

ELECTRICAL PERFORMANCES

Supply voltage	5 to 28 VDC unregulated
Power Consumption	10 mA max.
Zero measurement output	+/- 50 mV typ in Differential Mode (> 10 g) +/- 100 mV typ in Differential Mode (2 g and 5 g) 2500 mV DC +/- 150 mV in Single Ended Mode
Isolation	sensing element isolated from housing

ENVIRONMENTAL PERFORMANCES

Sensitivity	20 mV/g up to 2000 mV/g (Differential Mode)
Shock limit	4000 g (2 g and 5 g); 6000 g (>10 g)
Operation Temperature	- 50 °C to + 120 °C
Storage Temperature	- 55 °C to + 125 °C
Protection Class	IP68
Housing Material	Stainless Steel, welded
Mounting	4 holes for screw M2.5
Dimensions	22.0 x 22.0 x 11.0 mm (l x w x h)
Weight Housing	36 grams, without cable
Cable	4-wire shielded PUR-Cable, AWG 30
Cable Length	6 m
Cable Material	PUR, black
Cable Weight	12 grams per meter, Ø 3.0 mm

CABLE CODE DIFFERENTIAL

red = Excitation +
black = Excitation -

green = Signal +
white = Signal -

CABLE CODE SINGLE ENDED

red = Excitation +
black = Excitation -

green = Signal +

ORDER INFORMATION

BST 57K1-050-6Z
57K1 = Model Name
050 = Range 50 g
6 = 6 m Cable
Z = no connector

OPTIONAL

Additional Cable Length
Connector
TEDS
Dallas ID
Calibration DAkKS DIN EN ISO/IEC 17025:2018